



MachXO2 Control Development Kit

User's Guide

Introduction

Thank you for choosing the Lattice Semiconductor MachXO2™ Control Development Kit!

This guide describes how to start using the MachXO2 Control Development Kit, an easy-to-use platform for rapidly prototyping system control designs using MachXO2 PLDs. Along with the evaluation board and accessories, this kit includes a pre-loaded control system-on-chip (Control SoC) design that demonstrates board diagnostic functions including I/O control, voltage monitoring, time-stamps and data logging to non-volatile memory. The Power Manager II ispPAC®-POWR1014A and 8-bit LatticeMico8™ microcontroller are featured in the board and demonstration design.

The contents of this user's guide include demo operation, top-level functional descriptions of the various portions of the evaluation board, descriptions of the on-board connectors, switches, a complete set of schematics and bill of materials for the MachXO2 Control Evaluation Board.

Note: Static electricity can severely shorten the lifespan of electronic components. See the MachXO2 Control Development Kit QuickSTART Guide for handling and storage tips.

Features

The MachXO2 Control Development Kit includes:

- **MachXO2 Control Evaluation Board** – The MachXO2 Control Evaluation Board features the following on-board components and circuits:
 - MachXO2 LCMXO2-1200HC-csBGA132 PLD. The board is designed for density migration, allowing a higher-density MachXO2 device (up to 4000 LUTs) to be assembled on the board.
 - Part number LCMXO2-1200HC-C-EVN is populated with the R1 silicon. For more information on the R1 to Standard migration refer to the AN8086, [Designing for Migration from MachXO2-1200-R1 to Standard \(Non-R1\) Devices](#).
 - Power Manager II POWR1014A mixed-signal PLD
 - 4 Mbit SPI Flash memory
 - microSD (micro Secure Digital) memory socket
 - 60-ball VFBGA footprint for LPDDR memory. When populated, 128-Mbit LPDDR memory will be added to the board.
 - Current and voltage sensor circuits
 - Voltage ramp circuits
 - Electret microphone
 - Audio amplifier and Delta-Sigma ADC
 - PWM analog output circuit
 - Audio output channel
 - Up to two DVI sources and one DVI output
 - Up to two 7:1 LVDS sources and one 7:1:VDS output
 - Expansion header for JTAG, SPI, I²C and PLD I/Os
 - LEDs and switches
 - Standard USB cable for device programming
 - RS-232/USB and JTAG/USB interface
 - RoHS-compliant packaging and process
 - AC adapter (international plugs)
 - **Pre-loaded Reference Designs and Demo** – The kit includes the pre-loaded Control SoC demo design that integrates several Lattice reference designs including: the LatticeMico8 microcontroller, master WISHBONE bus controller, soft Delta-Sigma ADC, SPI master controller, UART peripheral, Embedded Block RAM and additional control functions.
 - **USB connector Cable** – A mini B USB port provides a communication and debug port via a USB-to-RS-232 physical channel and programming interface to the MachXO2 JTAG port.
-

- **AC Adapter** (international plugs) with 5V DC output.
- **QuickSTART Guide** – Provides information on connecting the MachXO2 Control Evaluation Board, installing Windows hardware drivers, and running the Control SoC demo.

Figure 1 shows the top side of the MachXO2 Control Evaluation Board with comments on the specific features that are designed in the board.

Figure 1. MachXO2 Control Evaluation Board, Top Side

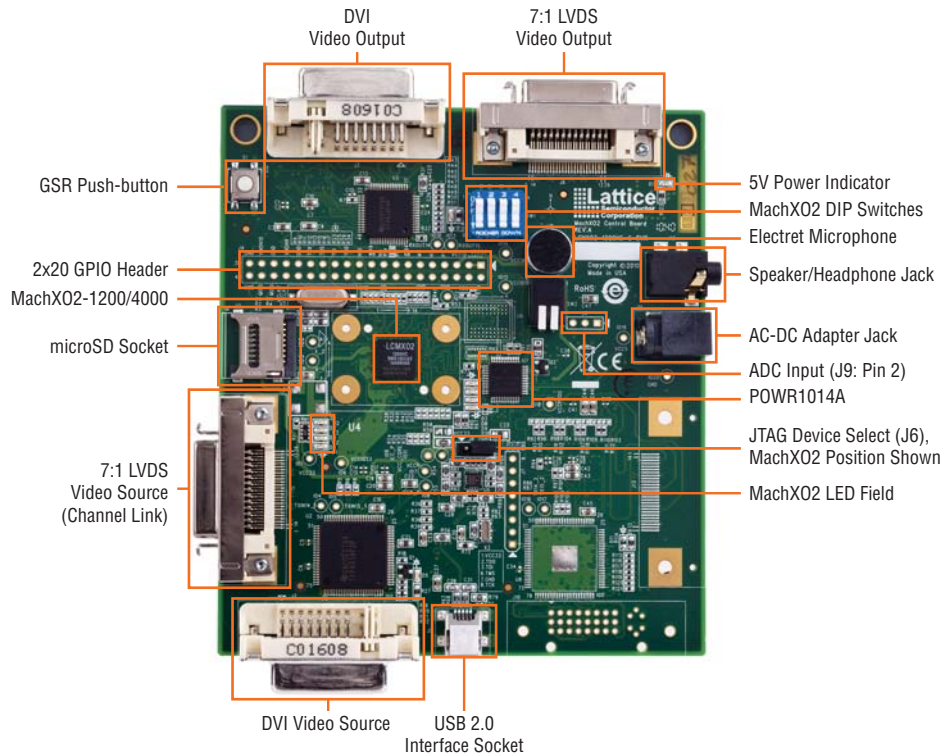

Note: The bill of materials of this board has the following limitations:

- *Video Source 1 is available in both DVI and 7:1 LVDS interfaces. Video Source 2 is not populated.*
- *LPDDR memory component is not populated. This feature will be populated with greater MachXO2 device density on the board.*
- *The initial MachXO2 device that is assembled on the board is LCMXO2-1200HC. The footprint is compatible with greater device densities and an LCMXO2-4000HC device is planned to be populated in future versions of the board.*

Lattice Semiconductor Devices

MachXO2

This board features a 3.3V MachXO2 PLD packaged in a 132-ball csBGA package. This package allows density migration to devices as large as 4340 LUTs. A complete description of this device can be found in the [MachXO2 Family Handbook](#).

Power Manager II

This board also features a Power Manager II mixed-signal PLD. The POWR1014A device serves as a general-purpose power supply monitor, reset generator, sequence controller, and high-voltage FET drivers. More information about Power Manager II devices can be found on the Lattice web site at www.latticesemi.com/products/powermanager.

Software Requirements

You should install the following software before you begin developing designs for the evaluation board:

- Lattice Diamond™ 1.2 or higher
- ispVM™ System 17.9.1 or higher

Control SoC Demonstration Design

The Control System-on-Chip (SoC) demonstration illustrates the use of the LatticeMico8 microcontroller, peripherals, and firmware integrated to provide system control features such as power supply sequencing, voltage monitoring, data logging to nonvolatile memory, I/O control, embedded block RAM utilization, UART communication and PLL status monitoring.

- The Power Manager II device sequences the power-up of voltage rails on the board and performs reset distribution.
- LatticeMico8 executable program initializes the peripherals that are embedded in the SoC design. During initialization, LatticeMico8 uploads the user menu on the HyperTerminal of a PC.
- Users interact with LatticeMico8 and the board through the HyperTerminal of a PC.

Figure 2. Control SoC Demo Block Diagram

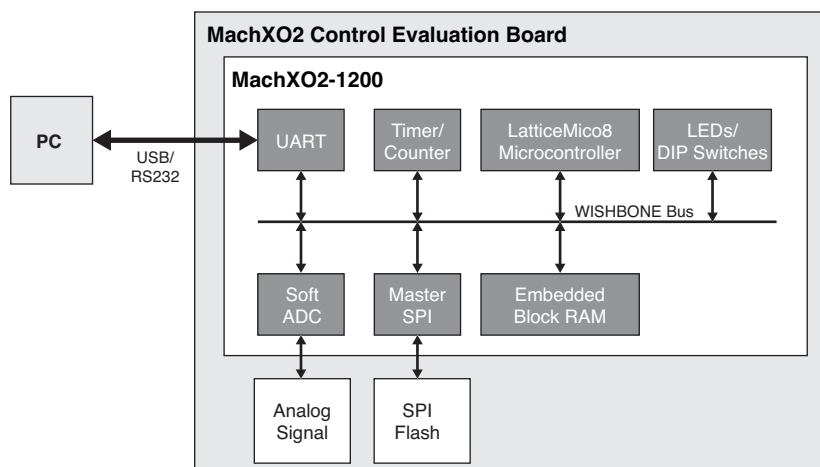

Power management is handled in two phases by the MachXO2 Control Evaluation Board system:

1. **Power On** – After power is supplied to the board and the 3.3V rail is stable, the POWR1014A sequences four supply rails. Two circuits demonstrate the voltage ramp of 2N7002E power MOSFETs using the high-voltage (HVOUT) outputs and two demonstrate power rail enable of VCC_CORE and VCCP of the MachXO2 using digital outputs. Next, the POWR1014A asserts the MachXO2 reset. Finally, the POWR1014A enters a supply monitoring state.
2. **Post Power On** – During the second phase of power management, the board's "condition" is monitored. Power supply rail voltage, and current is monitored by the POWR1014A. If any supply rail fails, the POWR1014A asserts a reset for the MachXO2.

MachXO2 Function – After the reset is de-asserted, LatticeMico8 initializes the peripherals embedded in the MachXO2 device and uploads the user menu onto the HyperTerminal window of a PC.

Figure 3. HyperTerminal User Menu

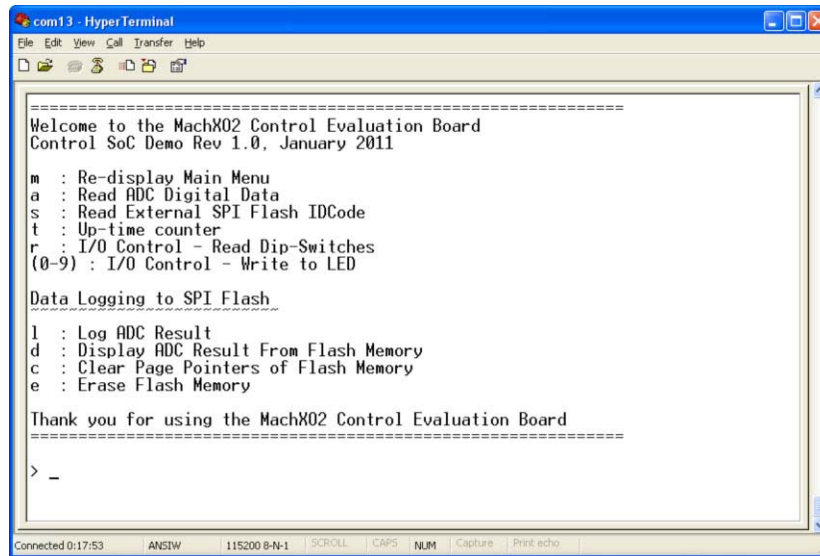
The image shows a screenshot of a HyperTerminal window titled 'com13 - Hyper Terminal'. The window displays a menu for the MachXO2 Control Evaluation Board. The text in the window is as follows:

```
=====
Welcome to the MachXO2 Control Evaluation Board
Control SoC Demo Rev 1.0, January 2011

m : Re-display Main Menu
a : Read ADC Digital Data
s : Read External SPI Flash IDCode
t : Up-time counter
r : I/O Control - Read Dip-Switches
(0-9) : I/O Control - Write to LED

Data Logging to SPI Flash

l : Log ADC Result
d : Display ADC Result From Flash Memory
c : Clear Page Pointers of Flash Memory
e : Erase Flash Memory

Thank you for using the MachXO2 Control Evaluation Board
=====
> _
```

The status bar at the bottom of the window shows 'Connected 0:17:53', 'ANSIW', '115200 8-N-1', 'SCROLL', 'CAPS', 'NUM', 'Capture', and 'Print echo'.

Users interact with LatticeMico8 microcontroller and the board by selecting the available options in the HyperTerminal menu. The available options are:

- ‘m’ – This option will re-display the main menu anytime during the demonstration.
- ‘a’ – This option will sample the voltage in the pin #2 of header J9. By default, the node is biased at 1.65V, which is half of the VCCIO = 3.30V. The voltage will be displayed in the HyperTerminal window. The ADC input voltage should be limited to the range 0 to 3.0V to avoid device damage.
- ‘s’ – This option will read the device ID of the SPI Flash on the board and display it in the HyperTerminal. The resulting ID is hexadecimal 0x44, which corresponds to AT25DF041A device.
- ‘t’ – This option samples and displays the elapsed time since the reset was de-asserted.
- ‘r’ - This option samples the DIP switches (reference designator SW1) on the board and displays the data in the HyperTerminal. Users can change the DIP switches on the board and press ‘r’ to display the new value.
- “0-9” – These are BCD numerical values that can be typed on the keyboard. The value will be received by LatticeMico8, which will update the LEDs (D0-D3) on the board.
- ‘l’ – This is a lower case ‘l’ character. Pressing ‘l’ will sample the voltage in pin #2 of header J9 and log the data in the SPI Flash device on the board. The WRITE page pointer will increment when ‘l’ is pressed. The initial value of the page pointer after power-up or after a reset is 0.
- ‘d’ – This option will read the data from SPI Flash device and display it on the HyperTerminal window. The READ page pointer will increment when ‘d’ is pressed. The initial value of the page pointer after power-up or after a reset is 0.
- ‘c’ – This option will clear (reset) the WRITE and READ page pointers.
- ‘e’ – This selection will perform a bulk-erase of the Flash memory in the SPI Flash device.

Setting up the Board

Drivers and Firmware

Before you begin, you will need to obtain the necessary hardware drivers for Windows from the Lattice web site.

1. Browse to the www.latticesemi.com/MachXO2-control-kit and locate the hardware device drivers for the USB interface.

2. Download the ZIP file to your system and unzip it to a location on your PC.

Linux Support:

The USB interface drivers for the evaluation board are included in Linux kernel 2.4.20 or greater including distributions compatible with Lattice Diamond design software (Red Hat Enterprise v.3, v.4 or Novell SUSE Enterprise v.10).

The Control SoC Demo is preprogrammed into the MachXO2 Control Evaluation Board, however over time it is likely that your board will be modified.

To download the demo source files and reprogram the MachXO2 Control Evaluation Board:

1. Download demo application source code from www.latticesemi.com/mxo2-control-kit.
2. Use `.IDemo_MachXO2_Control_SoC\project\control_soc_demo.jed` to restore the MachXO2280 Control SoC demo design.
3. Use `.IDemo_PM_Control_BM\project\bm_demo.jed` to restore the POWR1014A Board Management demo design.

Connecting to the MachXO2 Control Evaluation Board

1. Plug the AC-DC adopter to an outlet.
2. Power the board by inserting the AC-DC adopter into the power jack with reference designator J11. Once the connection is made, a red LED with reference designator D12 will illuminate.
3. Connect the evaluation board to your PC using the USB cable provided. The USB connector in the board has reference designator J5.
4. If you are prompted, "Windows may connect to Windows Update", select **No, not this time** from available options and click **Next** to proceed with the installation.
5. Choose the **Install from specific location (Advanced)** option and click **Next**.
6. Select **Search for the best driver in these locations** and click the **Browse** button to browse to the Windows driver folder created earlier. Select the **CDM 2.04.06 WHQL Certified** folder and click **OK**.
7. Click **Next**. A screen will display as Windows copies the required driver files. Windows will display a message indicating that the installation was successful.

Programming the PLDs

The three-pin header with reference designator J6 is used to select between the JTAG port of the MachXO2 or POWR1014A device. Installing a jumper in pins 1 and 2 of J6 will select the JTAG port of the POWR1014A device. Installing a jumper in pins 2 and 3 of J6 will select the JTAG port of the MachXO2 device.

Pin 1 of header J6 is marked on the silkscreen of the board with a white triangle as shown in Figure 4. This example shows the jumper installed in pins 2 and 3 of the J6 header and the JTAG port of the MachXO2 device has been selected.

Figure 4. J6 Header Used for Selecting the JTAG Port of the PLDs



Using ispVM System software, users can scan and perform JTAG operations, including programming, with the MachXO2 and POWR1014A devices.

Setting Up Windows HyperTerminal

You will use a terminal program to communicate with the evaluation board. The following instructions describe the Windows HyperTerminal program which is found on most Windows PCs. You may use another terminal program if desired although setup will be different. Windows 7 does not include HyperTerminal. Tera Term has been verified to work with Windows 7. For Linux, Minicom is a good alternative.

Note: This step uses the procedure for Windows XP users. Steps may vary slightly if using another Windows version.

1. From the **Start** menu, select **Control Panel > System**. The “System Properties” dialog appears.
2. Select the **Hardware** tab and click **Device Manager**. The “Device Manager” dialog appears.

Figure 5. Device Manager – COM Port



3. Expand the **Ports (COM & LPT)** entry and note the COM port number for the USB Serial Port.
4. From the **Start** menu, select **Programs > Accessories > Communications > HyperTerminal**. The HyperTerminal application and a “Connection Description” dialog appear.

Figure 6. New Connection – COM Port

5. Specify a Name and Icon for the new connection. Click **OK**. The “Connect To” dialog appears.
6. Select the COM port identified in Step 3 from the Connect using: list. Click **OK**.

Figure 7. Selecting the COM Port

7. The “COMn Properties” dialog appears where n is the COM port selected from the list.
8. Select the following Port Settings and click **OK**.
 - Bits per second: **115200**
 - Data bits: **8**
 - Parity: **None**
 - Stop bits: **1**
 - Flow control: **None**

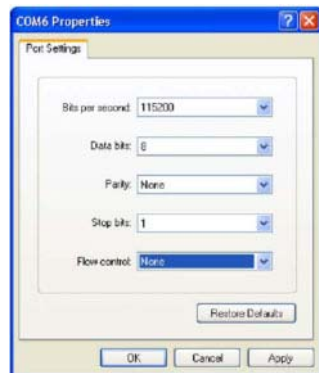
Figure 8. COM Port Properties

9. The HyperTerminal window appears.

10. From the MachXO2 Control Evaluation Board, press the reset push-button with reference designator S1. The Control SoC demo main menu appears.

Setting Up Linux Minicom

Minicom is a terminal program found with most Linux distributions. It can be used to communicate with the MachXO2 Control Evaluation Board.

To setup Minicom:

1. Check active serial ports:

```
#dmesg | grep tty
```

Note the tty label assigned to the USB port

2. From a command prompt, start Minicom:

```
#minicom -s
```

The configuration menu appears.

3. Highlight Serial port setup and press **Enter**. Serial port settings appear.
4. Press **A** (Serial Device). Specify the active serial device noted in Step 1 and press **Enter**.
5. Press **E** (Bps/Par/Bits). Specify **115200**, **None**, **8** and press **Enter**.
6. Press **F** (Hardware Flow Control). Specify **None** and press **Enter**.
7. Press **Esc**. The configuration menu appears.
8. Select **Save setup as dfl**. Minicom saves the port setup as the new default.
9. Select **Exit**. The Minicom interface appears.
10. From the evaluation board, press the **S1** push-button (GSR). The Control SoC demo main menu appears.

Ordering Information

Description	Ordering Part Number	China RoHS Environment-Friendly Use Period (EFUP)
MachXO2 Control Development Kit	LCMXO2-1200HC-C-EVN	

Technical Support Assistance

Hotline: 1-800-LATTICE (North America)
+1-503-268-8001 (Outside North America)
e-mail: techsupport@latticesemi.com
Internet: www.latticesemi.com

Revision History

Date	Version	Change Summary
April 2011	01.0	Initial release.
July 2011	01.1	Updated Features list with information on migration from MachXO2-1200-R1 to Standard (non-R1) devices.

© 2011 Lattice Semiconductor Corp. All Lattice trademarks, registered trademarks, patents, and disclaimers are as listed at www.latticesemi.com/legal. All other brand or product names are trademarks or registered trademarks of their respective holders. The specifications and information herein are subject to change without notice.

Appendix A. Schematic

Figure 9. Architecture

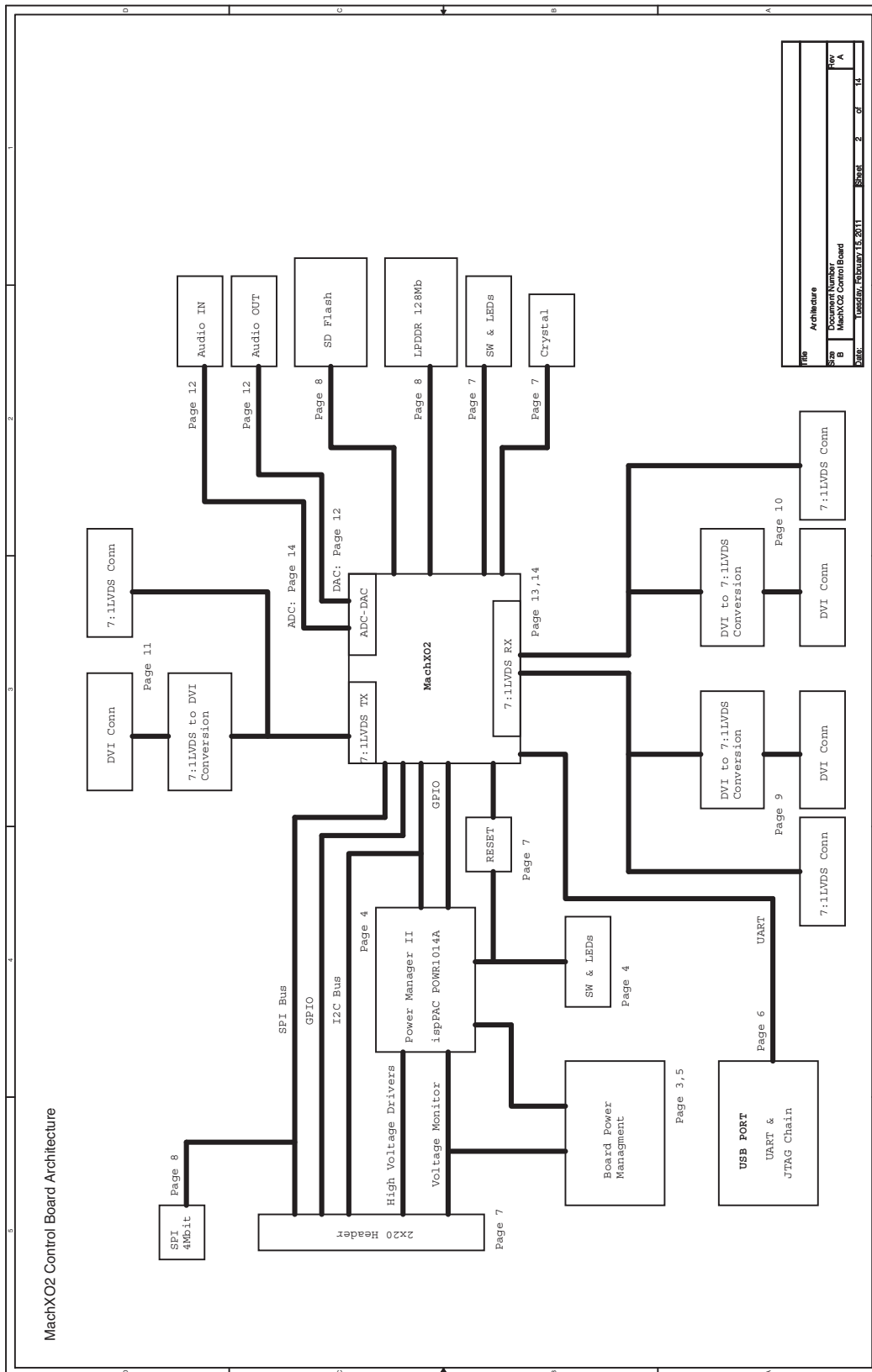

Figure 10. VCC33, VCC18, VCC12

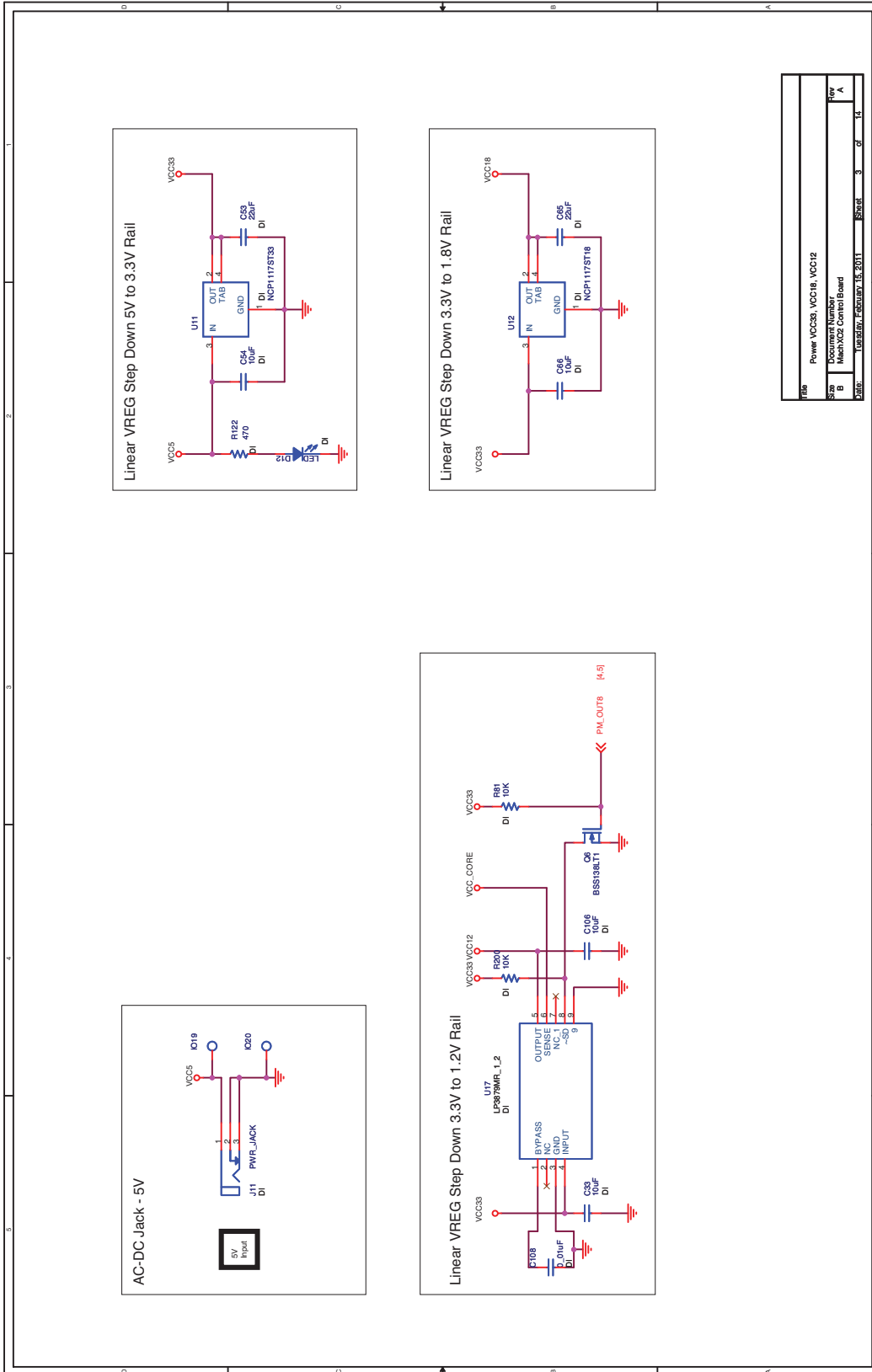

Figure 11. ispPAC-POWR1014A

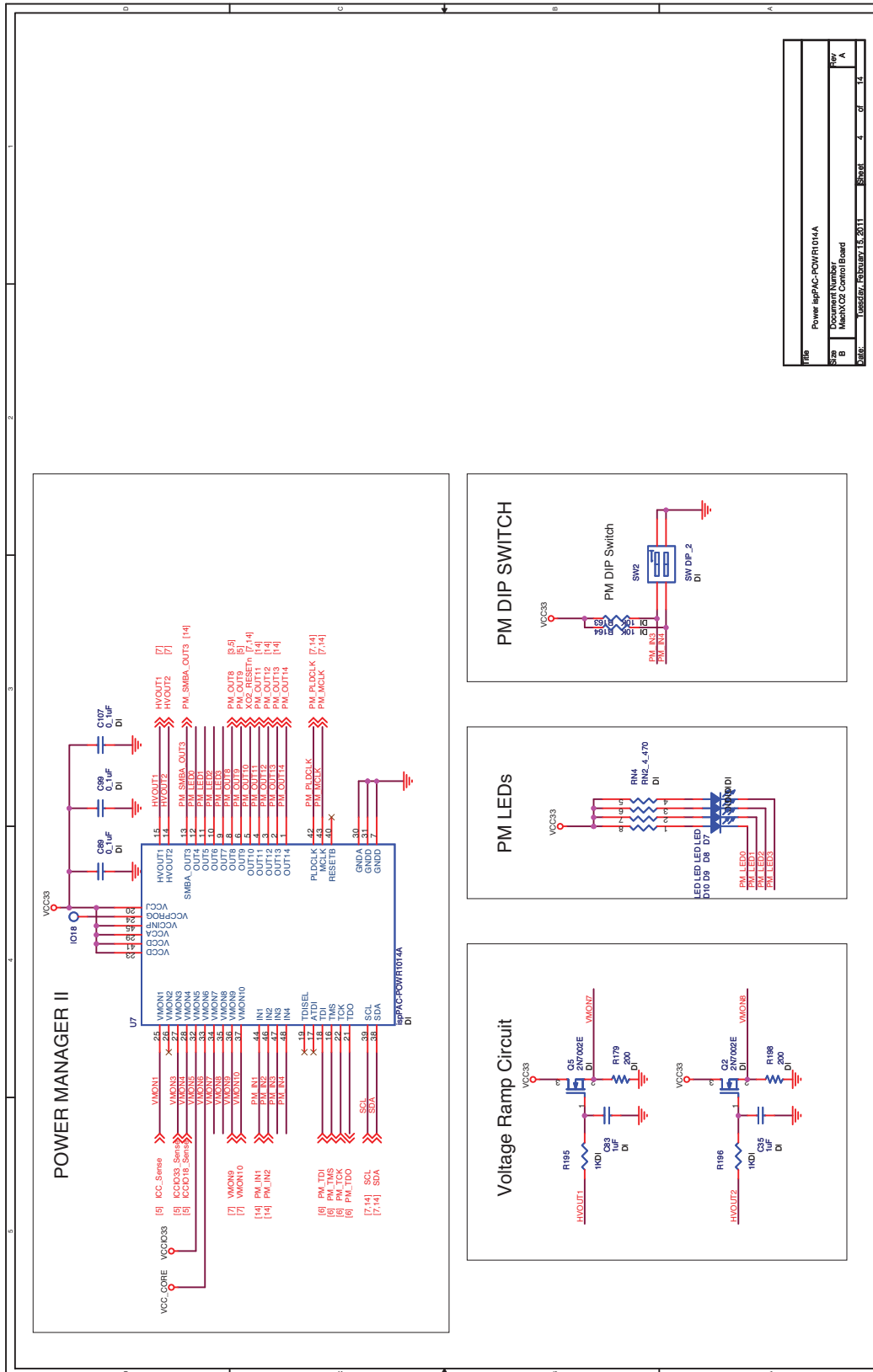

Figure 12. Power Current Sense

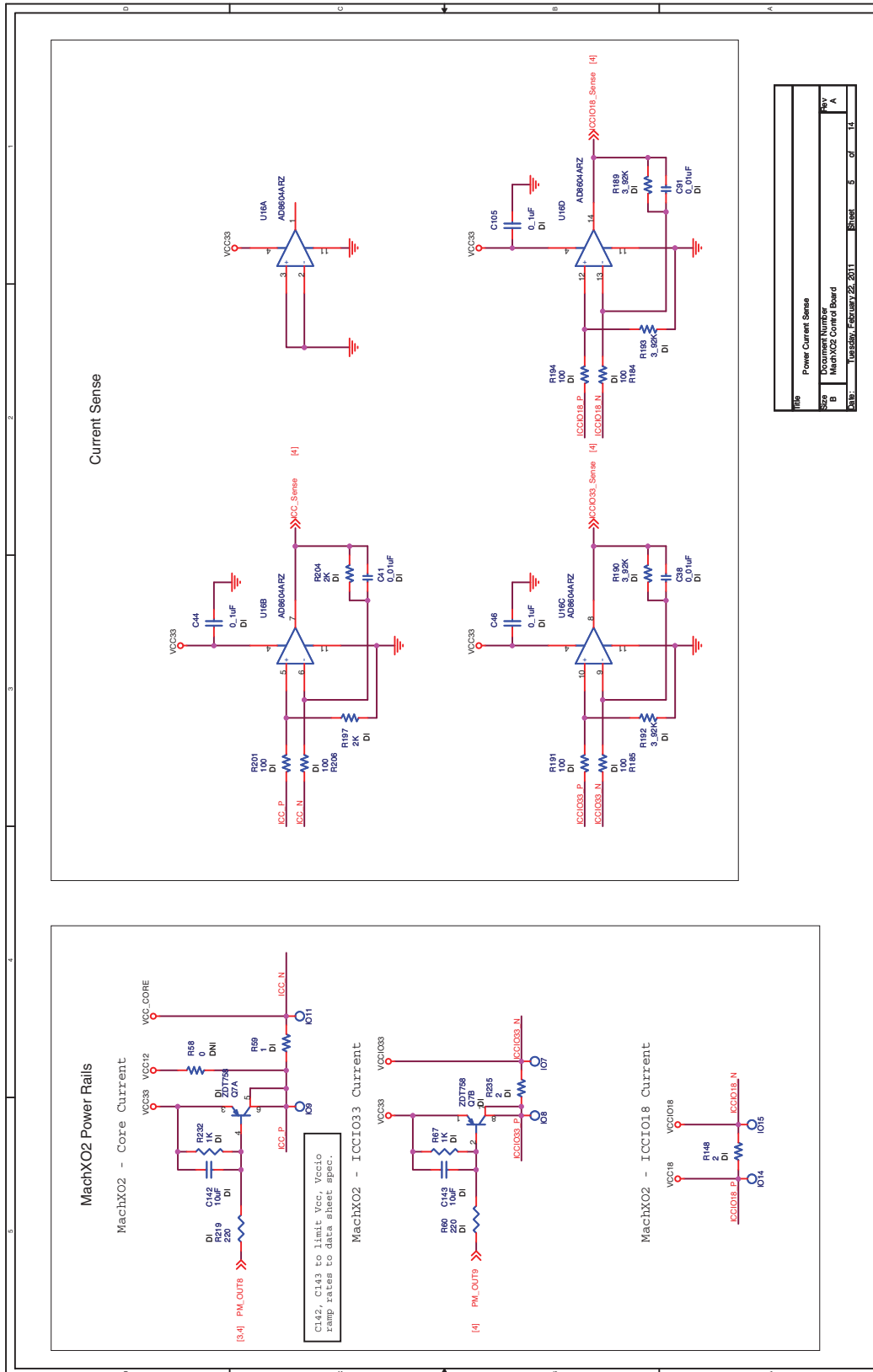

Figure 13. Configuration USB Port

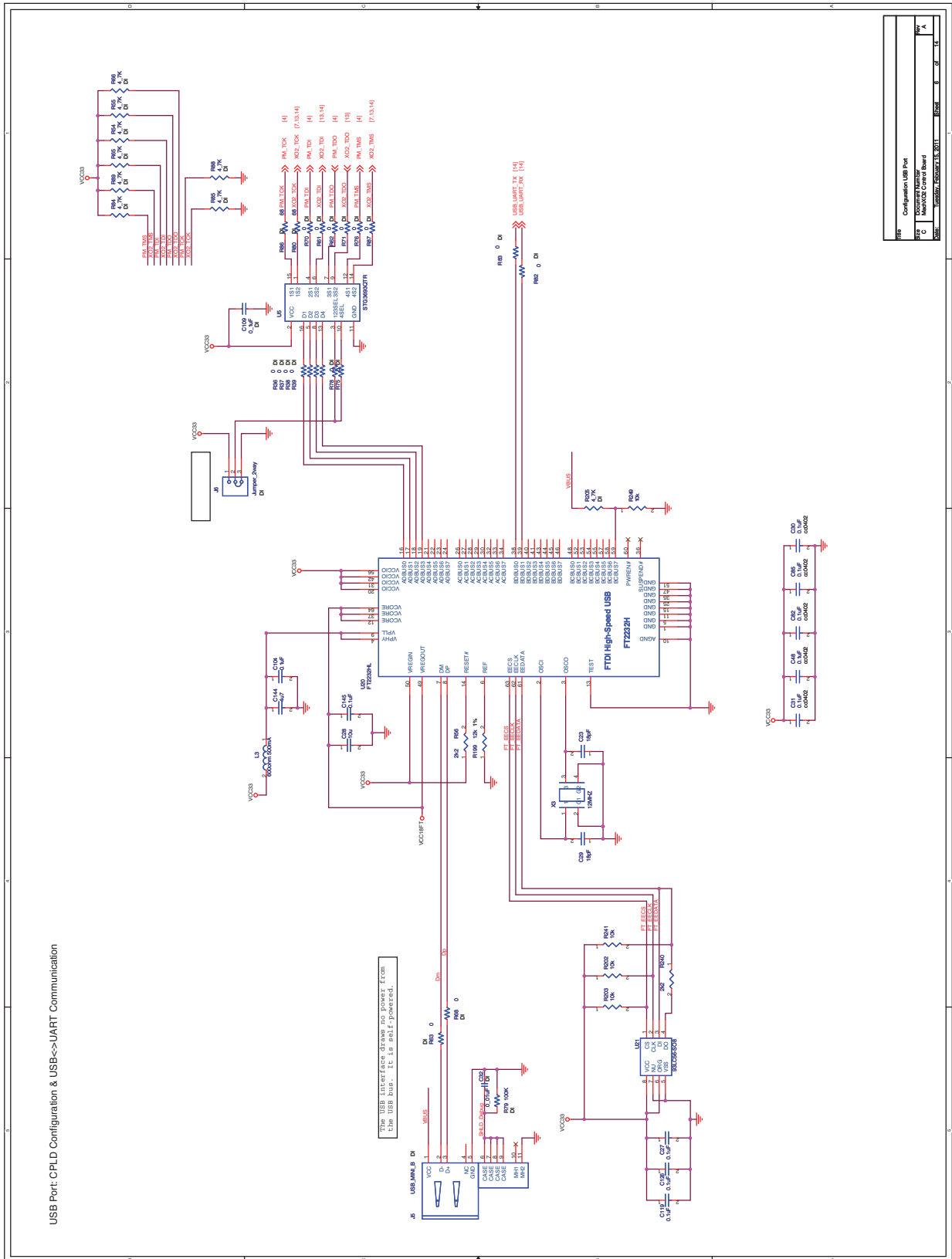

Figure 14. Software, LED, Crystal, Header

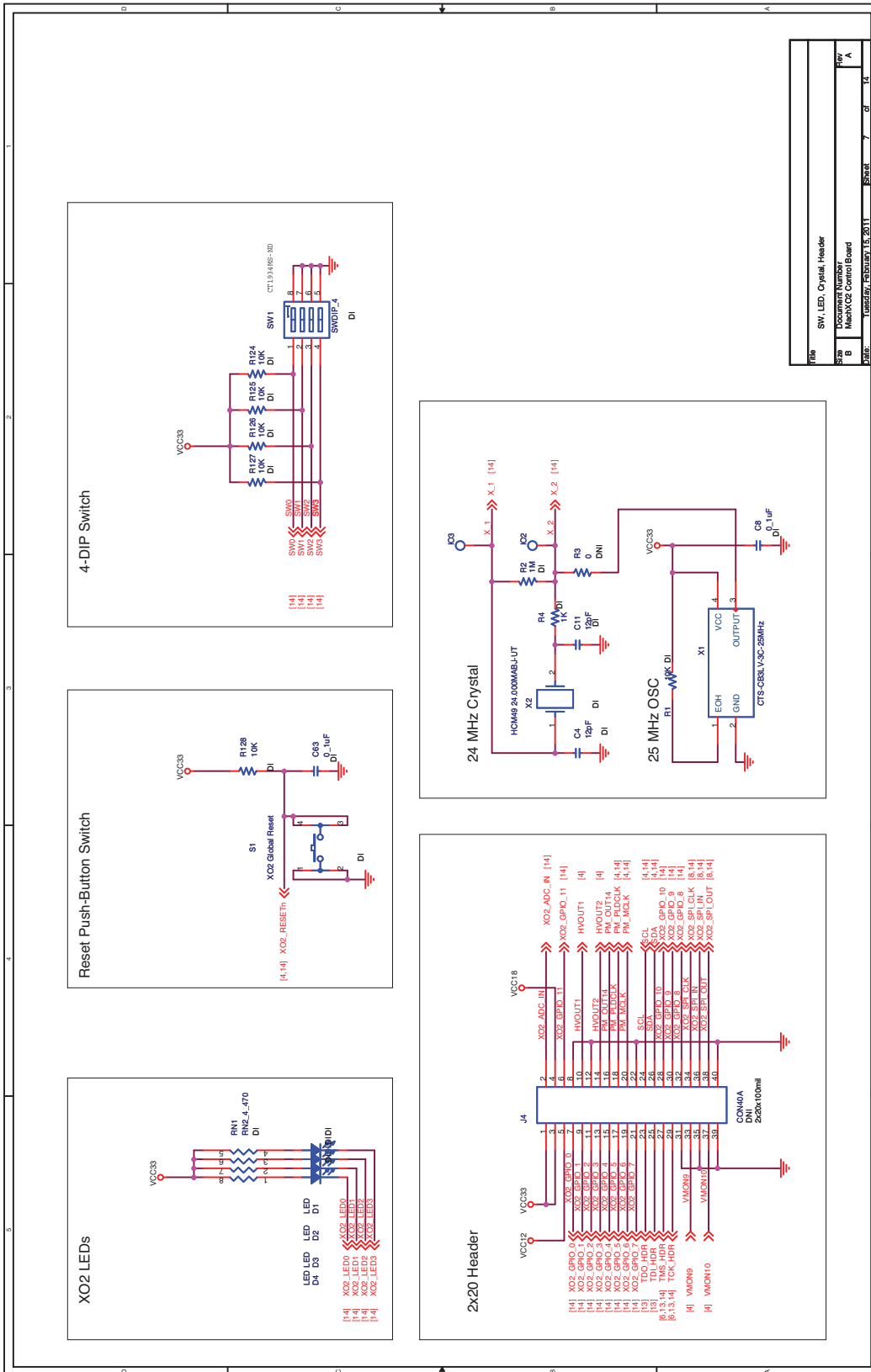
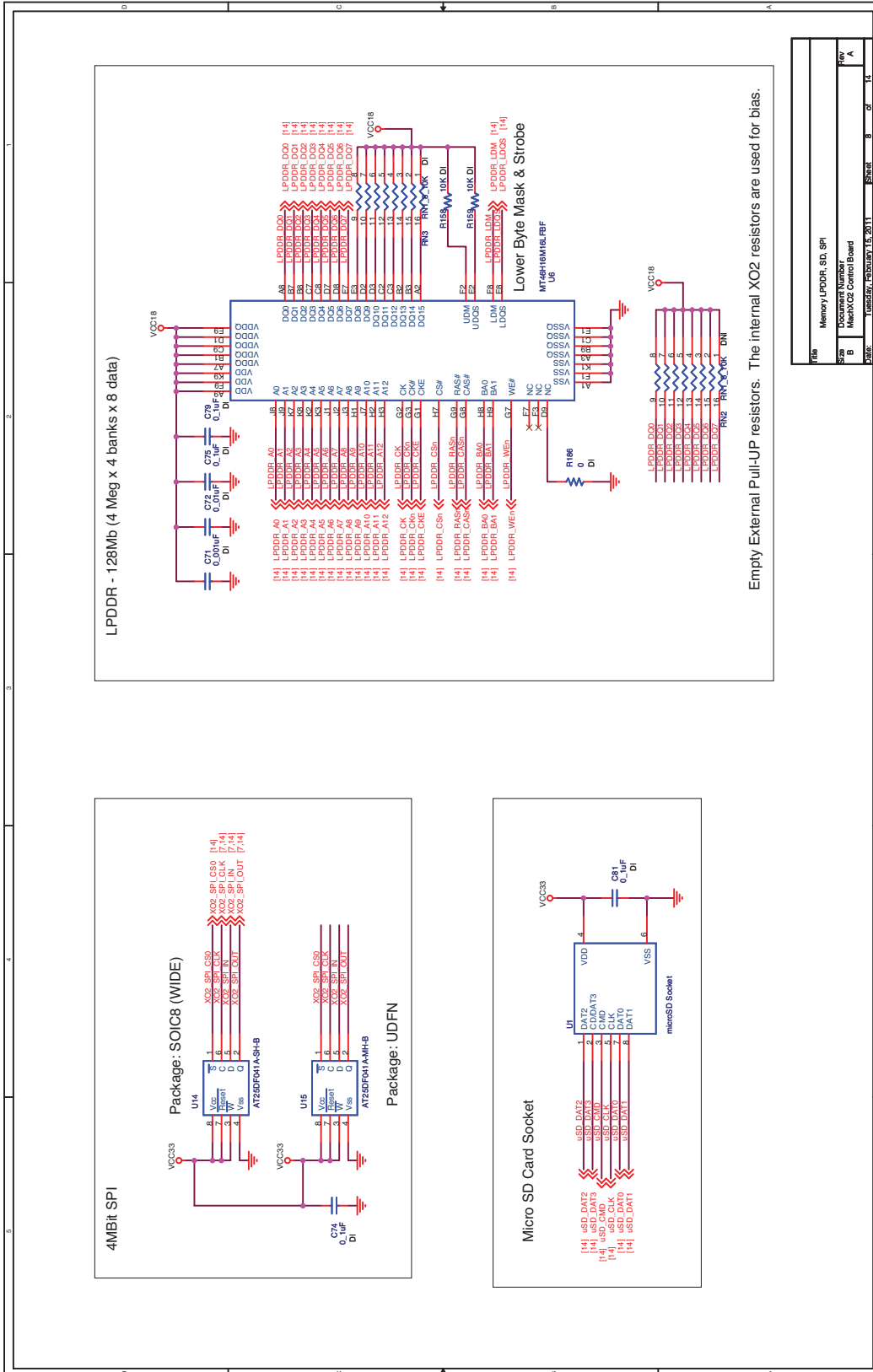

Figure 15. Memory LPDDR, SD, SPI



File	Memory LPDDR, SD, SPI
Doc Number	Doc 10000
Doc Name	MachXO2 Control Board
Date	February 16, 2011
Sheet	8 of 14
Rev	A

Figure 16. Video Input 1

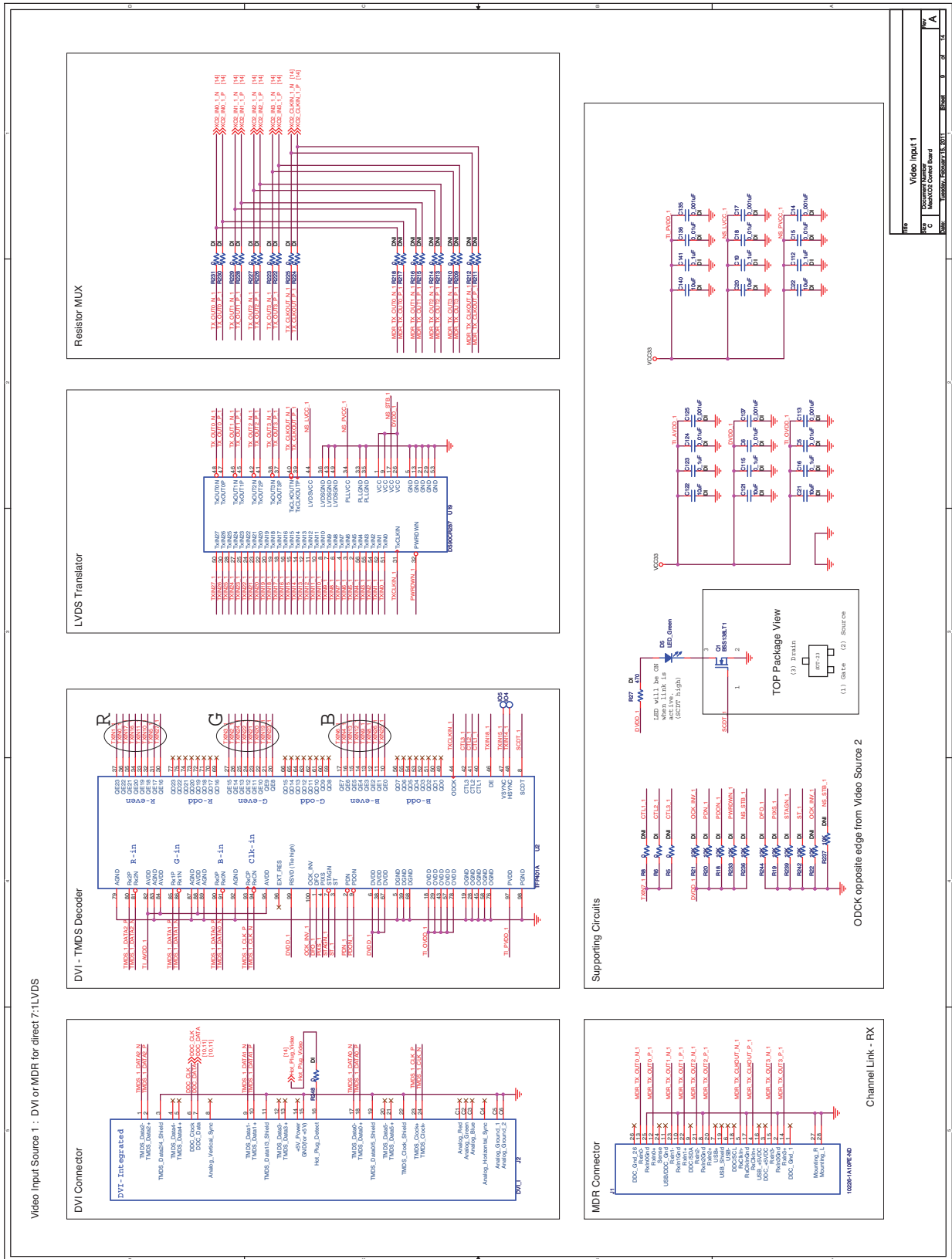

Figure 17. Video Input 2

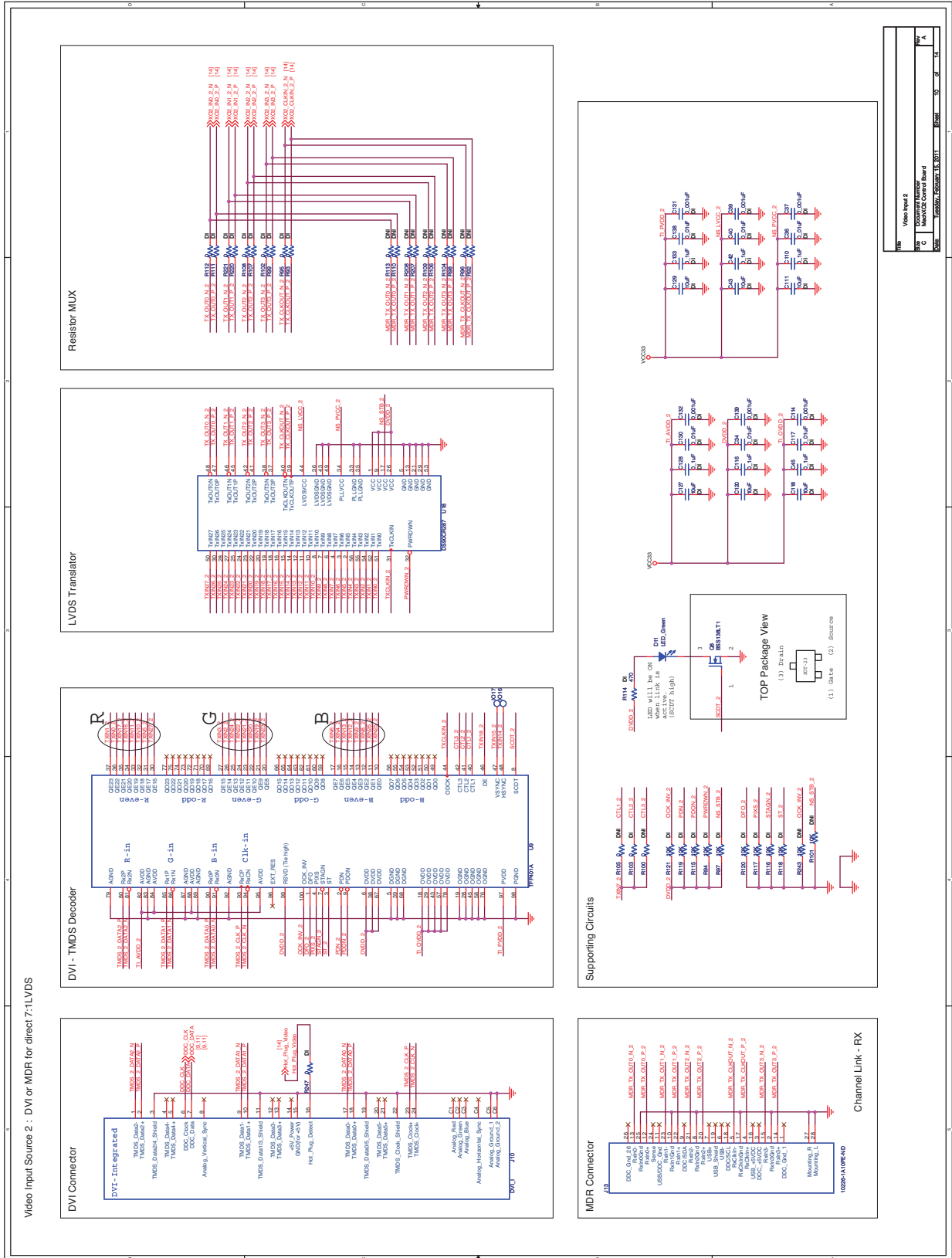

Figure 19. Audio In/Audio Out

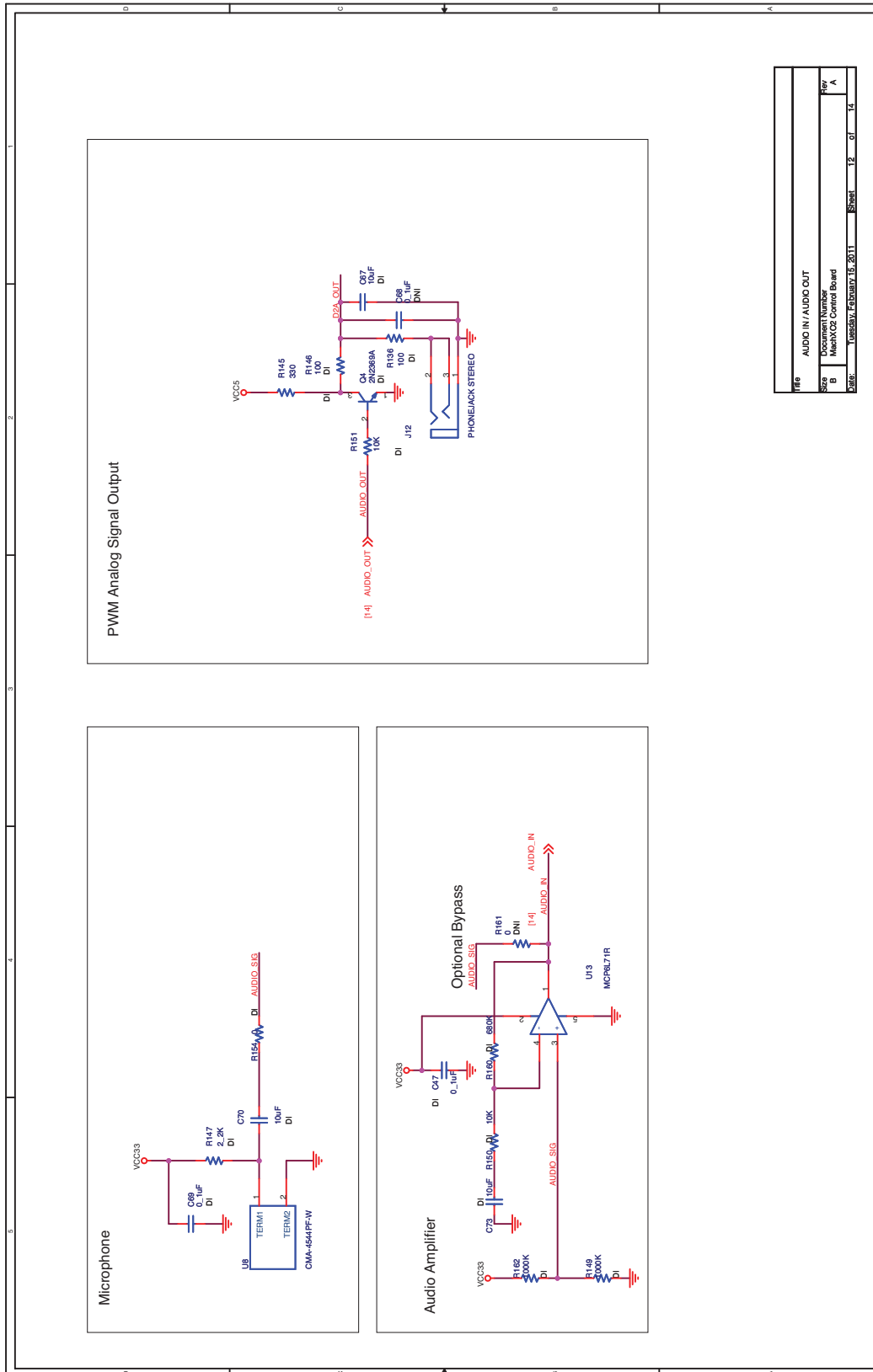
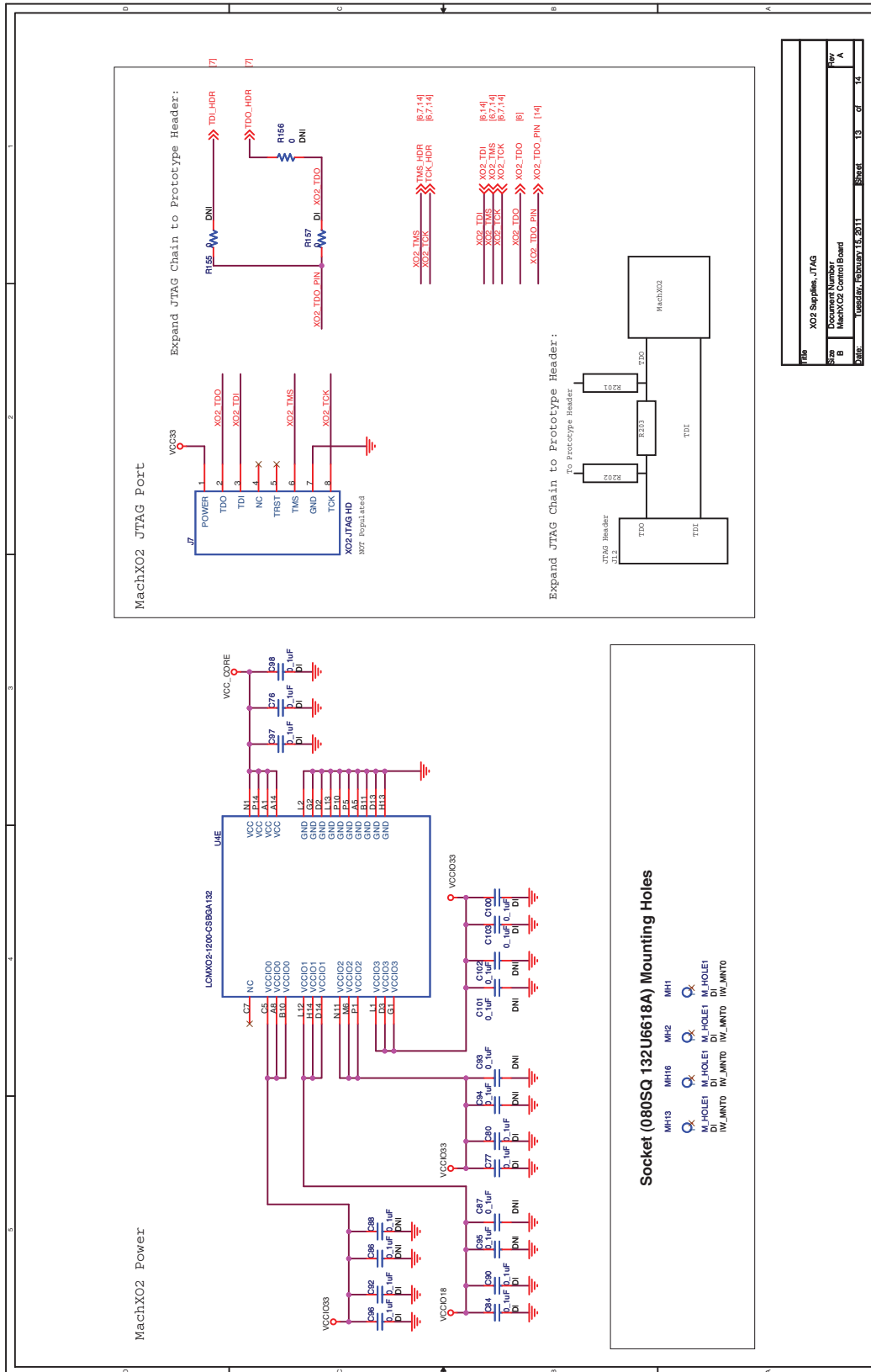
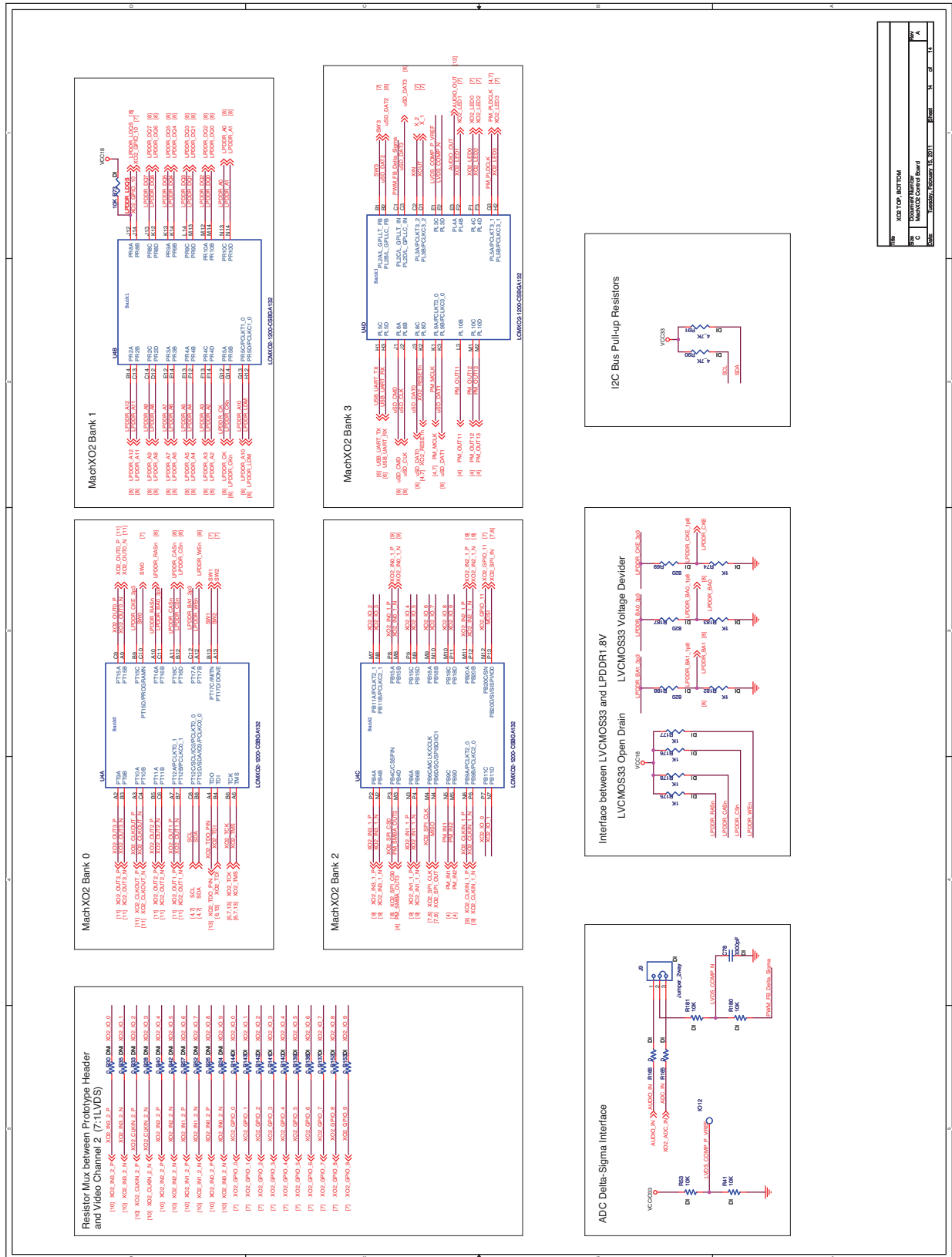

Figure 20. MachXO2 Supplies, JTAG



File	XO2 Supplies_JTAG
Size	Document Number
B	MachXO2 Control Board
Date	Issued by: February 18, 2011
	Sheet 13 of 14

Figure 21. MachXO2 Top, Bottom



Appendix B. Bill of Materials

Table 1. Bill of Materials

Item	Quantity	Reference	Value	PCB Footprint	Mfr Part Number	Manufacturer
1	19	C1, C7, C12, C14, C17, C26, C37, C39, C50, C55, C71, C113, C114, C125, C131, C132, C135, C137, C139	0_001uF	SM_C_0201		
2	23	C2, C5, C6, C15, C18, C24, C25, C32, C34, C36, C38, C40, C41, C51, C52, C56, C72, C91, C117, C124, C130, C136, C138	0_01uF	SM_C_0201		
3	18	C3, C9, C13, C20, C21, C22, C43, C49, C60, C62, C111, C118, C120, C121, C122, C127, C129, C140	10uF	SM_C_0603	C1608Y5V0J106Z	TDK
4	2	C4, C11	12pF	SM_C_0603		
5	32	C8, C10, C16, C19, C42, C44, C45, C46, C47, C57, C58, C59, C61, C63, C64, C69, C74, C81, C89, C99, C105, C107, C109, C110, C112, C115, C116, C123, C128, C133, C134, C141	0_1uF	SM_C_0603		
6	2	C23, C29	18pF	cc0402	C0402C180K3GACTU	Kemet
7	3	C27, C30, C31	0.1uF	cc0402	C0402C104K4RACTU	Kemet
8	1	C28	10u	cc0603	ECJ-1VB0J106M	Panasonic
9	4	C33, C106, C142, C143	10uF	SM_C_0805	JMK212BJ106KD-T	TAIYO YUDEN
10	2	C35, C83	1uF	SM_C_0805		
11	7	C48, C82, C85, C104, C119, C126, C145	0.1uF	cc0402	C0402C104K4RACTU	Kemet
12	2	C53, C65	22uF	SM_C_0805	LMK212BJ226MG-T	TAIYO YUDEN
13	4	C54, C66, C70, C73	10uF	SM_C_0805		
14	1	C67	10uF	SM_C_0603		
15	1	C68	0_1uF	SM_C_0603		
16	13	C75, C76, C77, C79, C80, C84, C90, C92, C96, C97, C98, C100, C103	0_1uF	SM_C_0201		
17	1	C78	3300pF	SM_C_0603		
18	8	C86, C87, C88, C93, C94, C95, C101, C102	0_1uF	SM_C_0201		
19	1	C108	0_01uF	SM_C_0201	EMK107BJ103K	TAIYO YUDEN
20	1	C144	4u7	cc0603	ECJ-1VB0J475K	
21	8	D1, D2, D3, D4, D7, D8, D9, D10	LED	SM_D_0603	LTST-C190CKT	LITE ON
22	2	D5, D6	LED_Green	SM_D_0603	LTST-C190KGKT	LITE ON
22a	1	D11	LED_Green	SM_D_0603	LTST-C190KGKT	LITE ON
23	1	D12	LED	SM_D_0603	LTST-C190CKT	LITE ON
24	15	IO2, IO3, IO4, IO5, IO9, IO10, IO11, IO12, IO13, IO14, IO16, IO17, IO18, IO19, IO20	T POINT R	TP		
25	3	IO7, IO8, IO15	T POINT R	TP		
26	2	J1, J8	10226-1A10PE-ND	10226-1A10PE-ND	10226-1A10PE	3M
26a	1	J13	10226-1A10PE-ND	10226-1A10PE-ND	10226-1A10PE	3M
27	2	J2, J3	DVI_I	DVI_I	74320-1004	Molex
27a	1	J10	DVI_I	DVI_I	74320-1004	Molex
28	1	J4	CON40A	2x20x100mil	TSW-120-07-G-D	Samtec
29	1	J5	USB_MINI_B	TYPE_B	UX60-MB-5ST	Hirose
30	1	J6	Jumper_2way	JP_2WY	TSW-103-07-G-S	Samtec Inc.
30	1	J9	Jumper_2way	JP_2WY	TSW-103-07-G-S	Samtec Inc.
31	1	J7	XO2 JTAG HD	XO2_JTAG_HD		
32	1	J11	PWR_JACK	PWR_CON	RAPC712	Switchcraft
33	1	J12	PHONEJACK STEREO	SM	MJ1-3510-SMT	CUI
34	1	L3	600ohm 500mA	FB0603	BLM18AG601SN1D	Murata
35	4	MH1, MH2, MH13, MH16	M_HOLE1	IW_MNT0	SJ-5003 (BLACK)	
36	4	Q1, Q3, Q6, Q8	BSS138LT1	SOT_23	BSS138LT3G	ON Semi
37	2	Q2, Q5	2N7002E	SM_SOT23	2N7002ET1G	ON_Semi

Table 1. Bill of Materials (Continued)

Item	Quantity	Reference	Value	PCB Footprint	Mfr Part Number	Manufacturer
38	1	Q4	2N2369A	2N2369A_SOT23	MMBT2369A	Fairchild
39	1	Q7	ZDT758	SM_8_DUAL_PNP	ZDT758	Diodes/Zetex
40	2	RN1, RN4	RN2_4_470	RN2_4_470_0603	TC164-JR-07470RL	Yageo
41	1	RN2	RN1_8_10K	RN1_8_10K_0603	MNR18E0APJ103	Rohm Semi
42	1	RN3	RN1_8_10K	RN1_8_10K_0603	MNR18E0APJ103	Rohm Semi
43	45	R1, R7, R18, R19, R20, R21, R32, R41, R43, R44, R45, R46, R47, R53, R73, R81, R94, R97, R115, R116, R117, R118, R119, R120, R121, R123, R124, R125, R126, R127, R128, R132, R151, R158, R159, R163, R164, R180, R181, R200, R233, R236, R239, R242, R244	10K	SM_R_0402		
44	1	R2	1M	SM_R_0603		
45	48	R3, R5, R8, R10, R11, R15, R16, R24, R25, R26, R28, R29, R30, R33, R35, R40, R42, R52, R57, R92, R96, R98, R100, R104, R105, R106, R109, R110, R113, R155, R156, R161, R168, R169, R172, R173, R207, R208, R209, R210, R211, R212, R213, R214, R215, R216, R217, R218	0	SM_R_0402		
46	5	R4, R67, R195, R196, R232	1K	SM_R_0603		
47	68	R6, R9, R12, R13, R14, R17, R23, R34, R36, R37, R38, R39, R49, R50, R51, R61, R62, R70, R71, R75, R76, R78, R82, R83, R87, R93, R95, R99, R102, R103, R107, R108, R111, R112, R131, R137, R138, R139, R140, R141, R142, R143, R144, R152, R153, R154, R157, R165, R166, R167, R170, R171, R174, R186, R220, R221, R222, R223, R224, R225, R226, R227, R228, R229, R230, R231, R247, R248	0	SM_R_0402		
48	7	R22, R48, R101, R237, R243, R245, R246	10K	SM_R_0402		
49	4	R27, R64, R114, R122	470	SM_R_0603	ERJ-3EKF4700V	Panasonic ECG
50	1	R31	510, 1%	SM_R_0603		
51	9	R54, R55, R65, R66, R84, R85, R88, R89, R205	4_7K	SM_R_0603		
52	1	R56	2k2	cr0402	TNPW04022K20BEED	Vishay/Dale
53	1	R58	0	SM_R_0805		
54	1	R59	1	SM_R_0805		
55	2	R60, R219	220	SM_R_0603		
56	2	R63, R68	0	SM_R_0603		
57	3	R69, R187, R188	820	SM_R_0402		
58	8	R74, R175, R176, R177, R178, R182, R183, R240	1K	SM_R_0402		
59	1	R79	100K	SM_R_0603		
60	2	R80, R86	68	SM_R_0402		
61	2	R90, R91	4_7K	SM_R_0402		
62	5	R129, R130, R133, R134, R135	100	SM_R_0603		
63	8	R136, R146, R184, R185, R191, R194, R201, R206	100	SM_R_0603		
64	1	R145	330	SM_R_0603		
65	1	R147	2_2K	SM_R_0603		
66	2	R148, R235	2	SM_R_0805		
67	2	R149, R162	1000K	SM_R_0603		
68	1	R150	10K	SM_R_0603		
69	1	R160	680K	SM_R_0603		
70	2	R179, R198	200	SM_R_0603		
71	4	R189, R190, R192, R193	3_92K	SM_R_0603		
72	2	R197, R204	2K	SM_R_0603		

Table 1. Bill of Materials (Continued)

Item	Quantity	Reference	Value	PCB Footprint	Mfr Part Number	Manufacturer
73	1	R199	12k	cr0402	RC0402FR-0712KL	Yageo
74	4	R202, R203, R241, R249	10k	cr0402	RC0402FR-0710KL	Yageo
75	0	R240	2k2	cr0402	RC0402FR-072K2L	Yageo
76	1	SW1	SWDIP_4	SMD_8check	3-5435640-5	Tyco
77	1	SW2	SW DIP_2	SP_75	195-2MST	CTS
78	1	S1	XO2 Global Reset	SMT_SW	EVQ-Q2K03W	Panasonic
79	1	U1	microSD Socket	SM_SD	460DE08C3	MULTICOMP
80	1	U2	TFP401A	HTQFP_100	TFP401APZPG4	TI
80	1	U9	TFP401A	HTQFP_100	TFP401APZPG4	TI
81	1	U3	TFP410	HTQFP_64	TFP410PAP	TI
82	1	U4	LCMXO2-1200- CSBGA132	CSBGA132	LCMXO2-1200- CSBGA132	Lattice Semi
83	1	U5	STG3693QTR	QFN	STG3693QTR	STMicro- electronics
84	1	U6	MT46H16M16LFBF	SM/60VFBGA	MT46H16M16LFBF	Micron
85	1	U7	ispPAC-POWR1014A	TQFP_48	ispPAC-POWR1014A- 01TN48I	Lattice
86	1	U8	CMA-4544PF-W	2 Solder Pins (TH)	CMA-4544PF-W	CUI Inc
87	1	U10	DS90CR288A	TSSOP_56	DS90CR288AMTD/NOP B	National Semi
88	1	U11	NCP1117ST33	SOT_223	NCP1117ST33T3G	ONsemi
89	1	U12	NCP1117ST18	SOT_223	NCP1117ST18T3G	ONsemi
90	1	U13	MCP6L71R	SOT_23_5_MC	MCP6L71RT-E/OT	Microchip
91	1	U14	AT25DF041A-SH-B	SOIC8	AT25DF041A-SH-B	Atmel
92	1	U15	AT25DF041A-MH-B	UDFN	AT25DF041A-MH-B	Atmel
93	1	U16	AD8604ARZ	14_SOIC	AD8604ARZ	Analog Devices
95	1	U17	Value	MRA08A_M	LP3879MR-1.2	National
96	1	U18	DS90CR287	TSSOP_56	DS90CR287MTD/NOPB	TI
96	1	U19	DS90CR287	TSSOP_56	DS90CR287MTD/NOPB	TI
97	1	U20	FT2232HL	tqfp64_0p5_12p2x12 p2_h1p6	FT2232HL	FTDI
98	1	U21	93LC56-SO8	so8_50_244	93LC56T-I/SN	Microchip
99	1	X1	CTS-CB3LV-3C-25MHz	SMD 7.00mm x 5.00mm	CB3LV-3C-25M0000	CTS
100	1	X2	HCM49 24.000MABJ-UT	SMD	HCM49 24.000MABJ-UT	Citizen Finetech
101	1	X3	12MHZ	crystal_4p_3p2x2p5	7M-12.000MAAJ-T	TXC CORP
102	1	XO2_Control_board_RevE_PCB	305-PD-11-XXX			